

BZ-15-130 (S,T), BZ-15-149 (S,T)

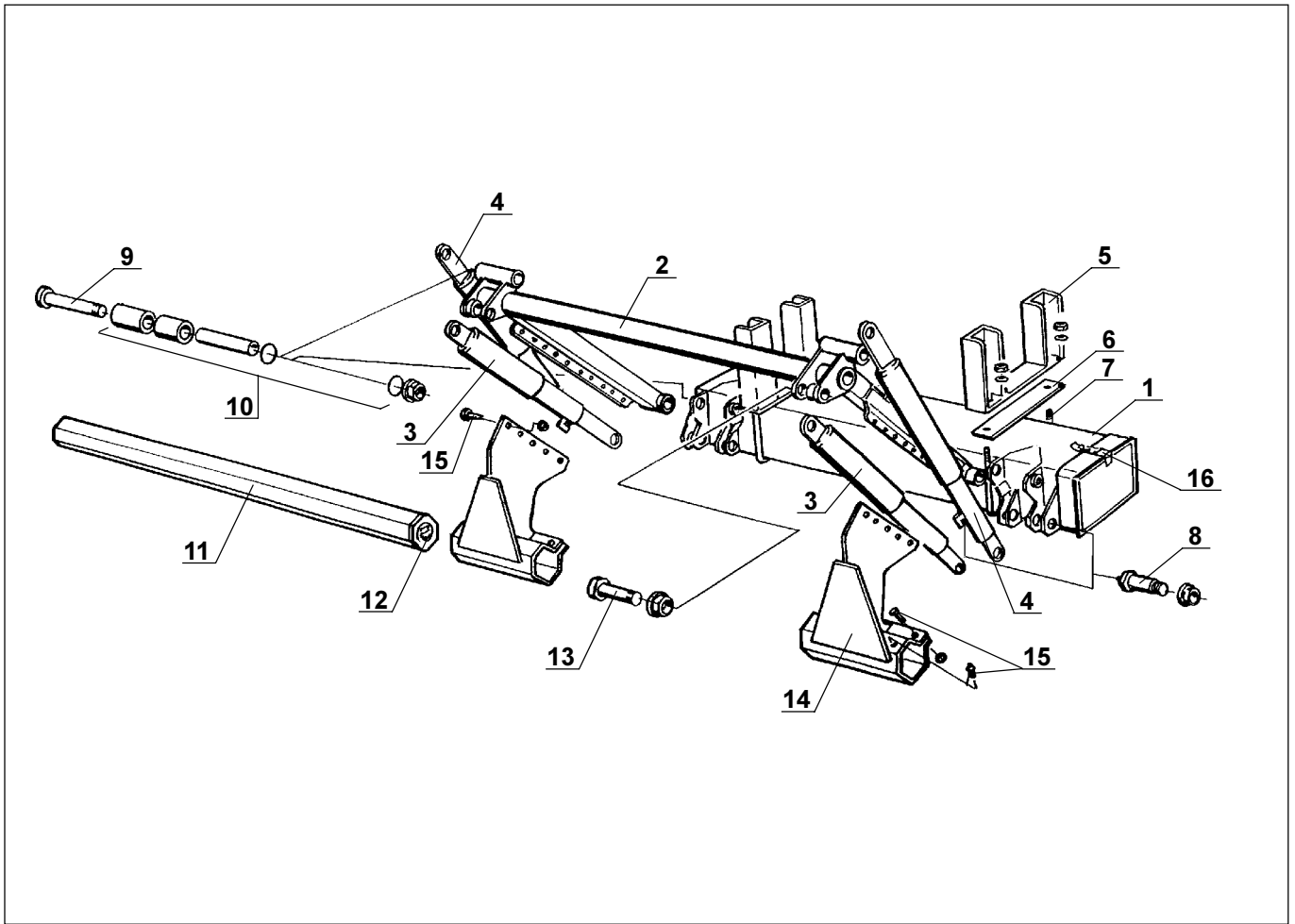

	BZ-15-130 S,T	BZ-15-149 S,T	S=Enkelverkande Lyft och Vipp T=Tvåhastighets vippcylinder	S=Single acting Lift and Tilt T=Two speed tilt cylinder	S=Einfachwirkende Hub und Kipp T=2 Geschwindigkeit kippzylinder	
Pos	Art no.	Art no.	Benämning (sida nr.)	Description (page no.)	Benennung (seite nr.)	Qty
.....	50170 ...	50170 ...	Hydraulenhet 6400 12 Volt (7.1)	Hydraulic Unit 6400 12 Volt (7.1)	Hyd. Einheit 6400 12 Volt (7.1)
.....	50171 ...	50171 ...	Hydraulenhet 6400 24 Volt (7.1)	Hydraulic Unit 6400 24 Volt (7.1)	Hyd. Einheit 6400 24 Volt (7.1)
.....	50214 ...	50214 ...	Hydraulenhet 6400 12 Volt (7.1)	Hydraulic Unit 6400 12 Volt (7.1)	Hyd. Einheit 6400 12 Volt (7.1)
.....	50221 ...	50221 ...	Hydraulenhet 6400 24 Volt (7.1)	Hydraulic Unit 6400 24 Volt (7.1)	Hyd. Einheit 6400 24 Volt (7.1)
1 ...	61859 ...	61859 ...	Stomme BZ-10/15	Support frame BZ-10/15	Kastenträger BZ-10/15	1 ...
2 ...	62144 ...		Armställ kpl. för lyfthöjd 1300mm	Lift arm cpl. for lift. height 1300 mm	Hubsch. kpl. für Hubhöhe 1300 mm	1 ...
2 ...		61846 ...	Armställ kpl. för lyfthöjd 1500mm	Lift arm cpl. for lift. height 1500 mm	Hubsch. kpl. für Hubhöhe 1500 mm	1 ...
3 ...	61031 ...		Lyftcylinder 1700 (5.2)	Lift cylinder 1700 (5.2)	Hubzylinder 1700 (5.2)	2 ...
3 ...		61029 ...	Lyftcylinder 1400 (5.2)	Lift cylinder 1400 (5.2)	Hubzylinder 1400 (5.2)	2 ...
4 ...	61032 ...		Vippcylinder 1800 T (5.3)	Tilt cylinder 1800 T (5.3)	Kippzylinder 1800 T (5.3)	2 ...
4 ...	65567 ...		Vippcylinder 1580 S (5.7)	Tilt cylinder 1580 S (5.7)	Kippzylinder 1580 S (5.7)	2 ...
4 ...		61030 ...	Vippcylinder 1500 T (5.3)	Tilt cylinder 1500 T (5.3)	Kippzylinder 1500 T (5.3)	2 ...
4 ...		61040 ...	Vippcylinder 1500-1 S (5.7)	Tilt cylinder 1500-1 S (5.7)	Kippzylinder 1500-1 S (5.7)	2 ...
5 ...	60381 ...	60381 ...	Ramfäste kpl.	Mounting bracket cpl.	Befestigungskonsole komplett	2 ...
6 ...	60386 ...	60386 ...	Distansplåt	Spacer	Distanzblech	2 ...
7 ...	31256 ...	31256 ...	Fästkrampa kpl.	U-clamp cpl.	Spannbügel	2 ...
8 ...	31281 ...	31281 ...	Ledbult kpl.	Pivot bolt cpl.	Gelenkbolzen komplett	4 ...
9 ...	31284 ...	31284 ...	Ledbult kpl.	Pivot bolt cpl.	Gelenkbolzen komplett	2 ...
10 ...	31100 ...	31100 ...	Bussning kpl.	Bushing cpl.	Plastikbüchse kpl.	4 ...
11 ...	31774 ...	31774 ...	U-skydd, sexkantrör L=2300 mm	Bumper bar tube L=2300 mm	Unterfahrerschutz rohr L=2300 mm	1 ...
12 ...	20281 ...	20281 ...	Plastgavel	Cover	Plastende	2 ...
13 ...	31283 ...	31283 ...	Ledbult kpl.	Pivot bolt cpl.	Gelenkbolzen komplett	2 ...
14 ...	31413 ...	31104 ...	Fäste för Underkörningsskydd	Bracket for bumper bar	Befestigungsblech	2 ...
15 ...	31154 ...	31154 ...	Skrivsats för Underkörningsskydd	Screw kit for bumper bar	Schraube satz für Unterfahrerschutz	1 ...
16 ...	32037 ...	32037 ...	Lås	Lock	Verschluss	1 ...