

# Hydraulenhet, Hydraulic unit, Hydraulische einheit

## 50309, 50311, 50313, 50314 (6500)

Fr.o.m prodnr: 117386  
 From prodno: 117386  
 Ab prodnr: 117386

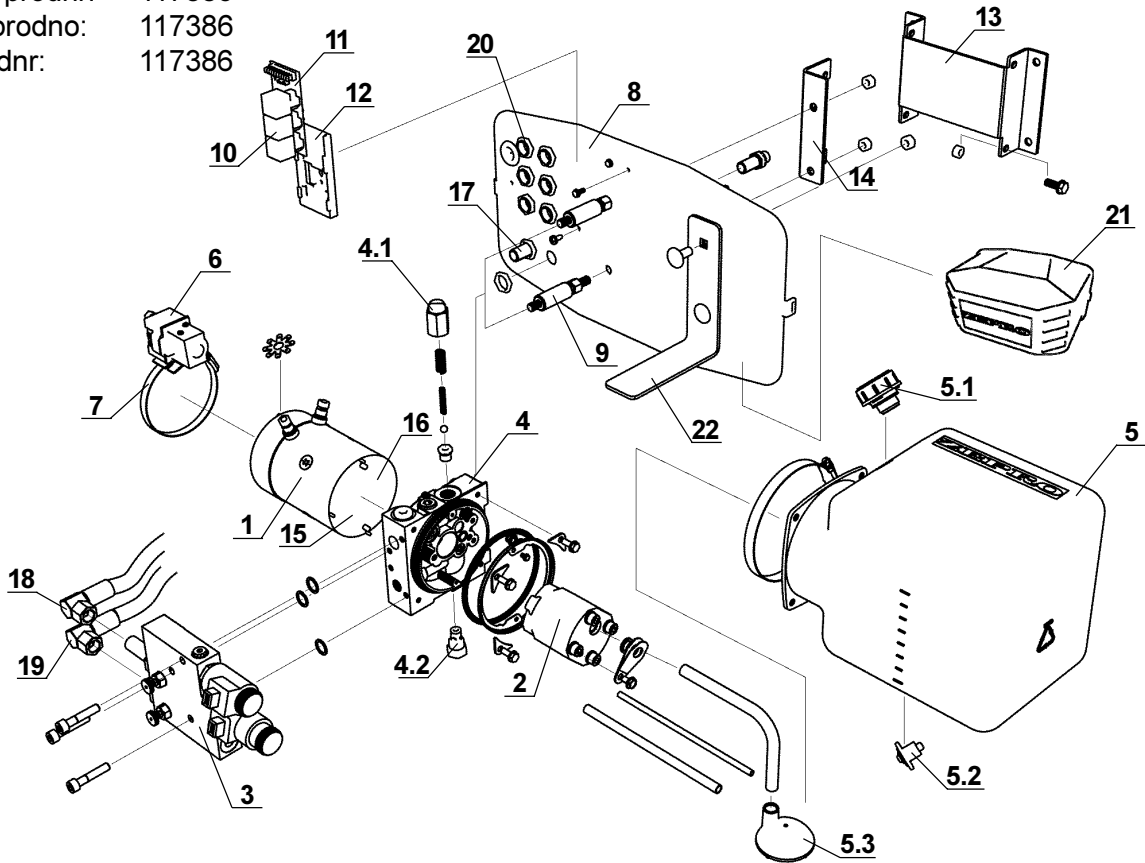

	6500	HYDRAULENHET	HYDRAULIC UNIT	HYDRAULISCHE EINHEIT	
Pos	Art no.	Benämning (sida nr.)	Description (page no.)	Benennung (seite nr.)	Qty
.....	50313 ...	Hydraulenhet 6500 12 Volt 130 bar .....	Hydraulic unit 6500 12 Volt 130 bar .....	Hydraulische einheit 6500 12 Volt 130 bar .....	.....
.....	50314 ...	Hydraulenhet 6500 24 Volt 130 bar .....	Hydraulic unit 6500 24 Volt 130 bar .....	Hydraulische einheit 6500 24 Volt 130 bar .....	.....
.....	50309 ...	Hydraulenhet 6500 12 Volt 170 bar .....	Hydraulic unit 6500 12 Volt 170 bar .....	Hydraulische einheit 6500 12 Volt 170 bar .....	.....
.....	50311 ...	Hydraulenhet 6500 24 Volt 170 bar .....	Hydraulic unit 6500 24 Volt 170 bar .....	Hydraulische einheit 6500 24 Volt 170 bar .....	.....
1 ...	32206 ...	Elmotor 2,0 kW 12 Volt .....	Electricmotor 2,0 kW 12 Volt .....	Elektromotor 2,0 kW 12 Volt .....	1 ...
1 ...	32207 ...	Elmotor 2,0 kW 24 Volt .....	Electricmotor 2,0 kW 24 Volt .....	Elektromotor 2,0 kW 24 Volt .....	1 ...
2 ...	32204 ...	Pump 2,5cc kpl. ....	Pump 2,5cc cpl. ....	Pumpe 2,5cc kpl. ....	1 ...
3 ...	32262 ...	Ventilsystem 12 Volt (7.38) .....	Valvesystem 12 Volt (7.38) .....	Ventil system 12 Volt (7.38) .....	1 ...
3 ...	32263 ...	Ventilsystem 24 Volt (7.38) .....	Valvesystem 24 Volt (7.38) .....	Ventil system 24 Volt (7.38) .....	1 ...
4 ...	31815 ...	Adapterblock kpl. ....	Adapterblock cpl. ....	Adaptergehäuse kpl. ....	1 ...
4.1	32213 ...	Överströmningsventil .....	Overflowvalve .....	Umgehungsventil .....	1 ...
4.2	32214 ...	Backventil .....	Checkvalve .....	Rückschlagklappe .....	1 ...
5 ...	32261 ...	Plasttank kpl. ....	Plasticreservoir kit .....	Kunststoffreservoir kpl. ....	1 ...
5.1	31810 ...	Tanklock .....	Filtercap .....	Tankdeckel .....	1 ...
5.2	32216 ...	Avtappningsplugg kpl. ....	Drain plug cpl. ....	Ölablasstutzen kpl. ....	1 ...
5.3	32217 ...	Sugfilter .....	Strainer .....	Saugfilter .....	1 ...
6 ...	20117 ...	Solenoid 12 Volt .....	Switch 12 Volt .....	Magnetschalter 12 Volt .....	1 ...
6 ...	20125 ...	Solenoid 24 Volt .....	Switch 24 Volt .....	Magnetschalter 24 Volt .....	1 ...
7 ...	32218 ...	Klammer .....	Brace .....	Klammer .....	1 ...
8 ...	50294 ...	Genomföringsplåt .....	Leading-in plate .....	Durchführungsplatte .....	1 ...
9 ...	50779 ...	Distansskruv .....	Distance screw .....	Distanzschraube .....	2 ...
10 ...	20361 ...	Relä 12Volt .....	Relay 12Volt .....	Relais 12Volt .....	3 ...
10 ...	20365 ...	Relä 24Volt .....	Relay 24Volt .....	Relais 24Volt .....	3 ...
11 ...	31122 ...	Kretskort .....	Circuitcard .....	Schaltplatte .....	1 ...
12 ...	64351 ...	Fäste kretskort .....	Bracket circuitcard .....	Befestigung Gedruckte schaltung .....	1 ...
13 ...	50297 ...	Konsol .....	Bracket .....	Konsole .....	1 ...
14 ...	50296 ...	Fästvinkel .....	Angle bracket .....	Befestigungsvinkel .....	2 ...
15 ...	32058 ...	Elborstesats 12 Volt .....	Carbon brush kit 12 Volt .....	Kohlborsten satz 12 Volt .....	1 ...
15 ...	32059 ...	Elborstesats 24 Volt .....	Carbon brush kit 24 Volt .....	Kohlborsten satz 24 Volt .....	1 ...
16 ...	32060 ...	Tempvakt .....	Heat gaurd .....	Temperatur wächter .....	1 ...
17 ...	31834 ...	Adapter .....	Adapter .....	Adapter .....	2 ...
18 ...	21996 ...	Hydraulslang 3/8" L=210 .....	Hydraulic hose 3/8" L=210 .....	Hydraulik Schlauch 3/8" L=210 .....	1 ...
19 ...	21997 ...	Hydraulslang 3/8" L=190 .....	Hydraulic hose 3/8" L=190 .....	Hydraulik Schlauch 3/8" L=190 .....	1 ...
20 ...	21605 ...	Kabelgenomföring .....	Conduit entry .....	Kabeldurchführung .....	5 ...
21 ...	50726 ...	Huv .....	Cover .....	Deckel .....	1 ...
22 ...	50295 ...	Tankhållare .....	Tank bracket .....	Tankhalter .....	1 ...
.....	31836 ...	O-rings sats (7.31) .....	O-ring set (7.31) .....	O-ring satz (7.31) .....	1 ...
.....	20364 ...	Skyddshuv kretskort .....	Cap for relays .....	Haube schaltplatte .....	1 ...