

CONVENTIONAL

P-80

IN 1,000 LB. LOAD CAPACITY

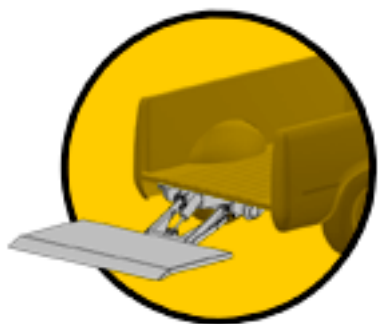

**A LIFTGATE SPECIFICALLY
DESIGNED TO MEET THE
DEMANDS OF LIGHT-DUTY
APPLICATIONS**

STANDARD EQUIPMENT

- [Electropak](#)
- [Power unit weather protective box](#)
- [SuperSwitch \(permanent mount\)](#)
- [Powder Coat Paint System](#)

SPECIFICATIONS

Model	Lifting Capacity	Platform Load Area	Ramp	Approx. Weight
P-80	1000 lbs.	30" x 50"	6"	320 lbs.
P-80	1000 lbs.	30" x 72"	6"	400 lbs.

MOUNTING REQUIREMENTS

Model	Bed Height Range	"A" Dimension	Mount Frame Clearance
P-80	24" - 44"	11" - 19.75"	18.5" - 26.5"

Important when determining **Bed Height Range**: The lesser dimension refers to vehicle loaded to maximum weight capacity. The greater dimension refers to vehicle when empty.

Mounting diagram not applicable.