

Ventil system, Valve system, Ventil system

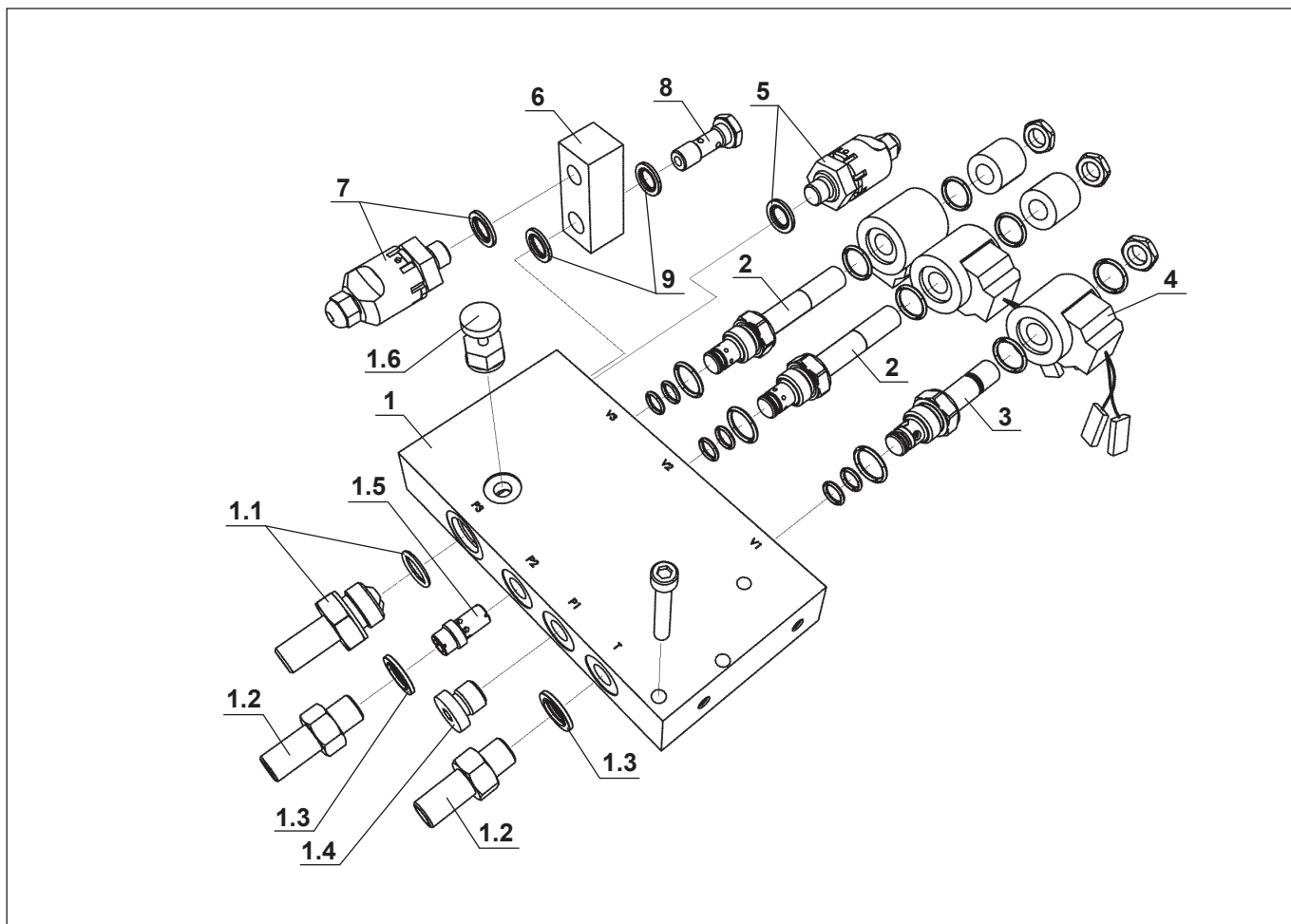

		VENTILSYSTEM	VALVE SYSTEM	VENTILSYSTEM	
Pos	Art no.	Benämning (sida nr.)	Description (page no.)	Benennung (seite nr.)	Qty.
.....	32836....	Ventilsystem 12 Volt (exkl. 6,7,8 och 9).....	Valve system 12 Volt (excl. 6,7,8 och 9).....	Ventil System 12 Volt (ohne 6,7,8 och 9)....
.....	32837....	Ventilsystem 24 Volt (exkl. 6,7,8 och 9).....	Valve system 24 Volt (excl. 6,7,8 och 9).....	Ventil System 24 Volt (ohne 6,7,8 och 9)....
1.....	32773....	Ventilhus kpl.	Valve housing cpl.....	Ventilgehäuse kpl.	1.....
1.1..	32827....	Adapter inkl. o-ring	Adapter incl. o-ring	Adapter mit o-ring	1.....
1.2..	21498....	Adapter	Adapter	Adapter	2.....
1.3..	20942....	Bricka	Washer	Scheibe	2.....
1.4..	20515....	Plugg	Plug	Propfen	1.....
1.5..	32828....	Konstantflödesventil 5 l/min.....	Constast flow valve 5 l/min.....	Rückflussbromsventil 5 l/min	1.....
1.6..	31850....	Justerskruv inkl. bricka	Adjusting screw incl. washer	Stellschraube mit Scheibe	1.....
2.....	32829....	Ventil exkl. magnet	Valve excl. magnet	Ventil ohne Magnet	2.....
3.....	32830....	Ventil exkl. magnet	Valve excl. magnet	Ventil ohne Magnet	1.....
4.....	32764....	Magnet 12 Volt	Magnet 12 Volt.....	Magnet 12 Volt	3.....
4.....	32768....	Magnet 24 Volt	Magnet 24 Volt.....	Magnet 24 Volt	3.....
5.....	21775....	Tryckvakt 60bar	Pressure guard 60bar	Druckwächter 60bar	1.....
6.....	53539....	Tryckvaktsblock	Pressure guard block.....	Druckwächter block	1.....
7.....	54939....	Tryckvakt 210bar	Pressure guard 210bar.....	Druckwächter 210bar	1.....
8.....	52012....	Hålskruv.....	Swivel joint.....	Lochschraube	1.....
9.....	20942....	Bricka.....	Washer	Scheibe.....	1.....